

UPC CFI, Local Division Paris, 21 May 2024, ARM v ICPillar

*system and method for universal control  
of electronic devices*

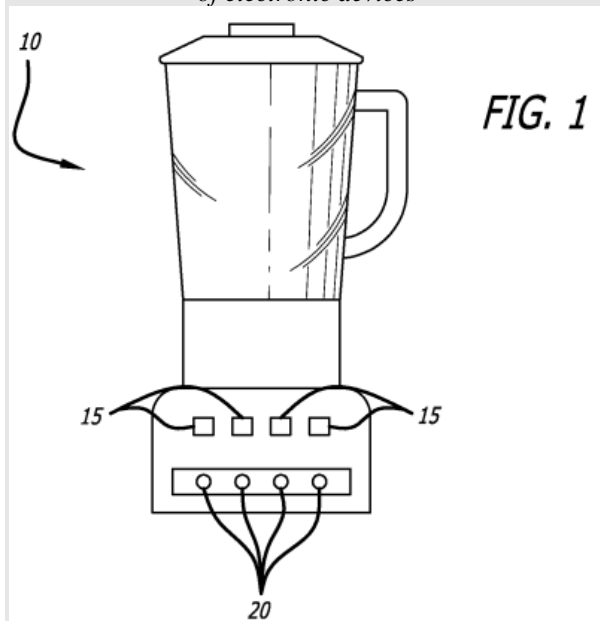

#### PATENT LAW – PROCEDURAL LAW

Security for costs of € 400.000 ordered because of potential inability for Claimant to cover the legal costs in case of losing ([Article 69\(4\) UPCA](#), [Rule 158\(1\) RoP](#))

- Factors to be considered when ordering a security order include the financial position of the other party that may give rise to a legitimate and real concern that a possible cost order might not be recoverable and/or the likelihood that a possible cost order by the UPC may not, or in an unduly burdensome way, be enforceable.
- In the present case, there are no exceptional circumstances that would be considered as unduly burdensome to justify the order. Nor does the mere fact that the Respondent is domiciled in the United States of America justify an order for security for costs.
- The Court therefore considers that we are in a situation of a potential risk of inability to cover the legal costs of the other party in case of losing the litigation, taking into account the value of the case, even if this amount is disputed, being declared by the Claimant at 18,000,000 EUR and hence leading to ceiling of the legal costs for the amount of EUR 1,200,000.

Applicants submitted that there are no public records about Respondent's assets and financial situation. They rightly pointed out that ICPILLAR presented itself in the statement of claim as a company founded in January 2021 by the inventor of the patent at issue, Mr. Seidner, and that ICPILLAR's only income was from the licensing of its patents. The official documents

submitted did not provide any information about ICPILLAR's financial situation or its current assets. Respondent in its written comments did not provide any indication of its financial situation.

- insurance taken out to cover the financial risks is insufficient for two reasons. Firstly, the purpose of this type of insurance is to provide a financial protection for ICPILLAR (the insured party), and not to protect the potential rights of the ARM entities (the applicants of the Security for cost request). Secondly, the full terms of the said insurance have not been disclosed and it is hence unclear what are the actual terms of the insurance.

Source: [Unified Patent Court](#)

**UPC Court of First Instance,  
Local Division Paris, 21 May 2024**

(Lignieres, Gillet, Rinkinen)

Paris Local Division

UPC\_CFI\_495/2023

Procedural Order

of the Court of First Instance of the Unified Patent Court delivered on 21/05/2024

concerning Security for Costs

#### APPLICANTS

**ARM Limited** (Defendant No. 1 in the main proceedings) 110 Fulbourn Road CB1 9NJ - Cambridge - GB

**Allinea Software GmbH** (Defendant No. 2 in the main proceedings) c/o Grant Thornton GmbH, Ganghoferstrasse 31 80339 - München - DE

**Apical Limited** (Defendant No. 3 in the main proceedings) 110 Fulbourn Road CB1 9NJ - Cambridge - GB

**Arm France SAS** (Defendant No. 4 in the main proceedings) Batiment B - 732 Avenue de Roumanille 06410 - Biot - FR

**Arm Germany GmbH** (Defendant No. 5 in the main proceedings) Bretonischer Ring 16 85630 - Grasbrunn - DE

**Arm Germany d.o.o** (Defendant No. 6 in the main proceedings) Obrtna Cesta 18 SL-8310 - Sentjernej - SI

**Arm Ireland Limited** (Defendant No. 7 in the main proceedings) Lyrr Building, 3, Mervue Business Park Galway Co. Galway - Galway - IE

**Arm Poland Sp. z.o.o** (Defendant No. 8 in the main proceedings) UL. ŻELAZNA 2 40-851 - KATOWICE, ŚLĄSKIE - PL

**Arm Sweden AB** (Defendant No. 9 in the main proceedings) Emdalavagen 6 SE-223 69 - Lund - SE

**Simulity Labs Limited** (Defendant No. 10 in the main proceedings) 110 Fulbourn Road CB1 9NJ - Cambridge - GB

**SVF Holdco Limited** (Defendant No. 12 in the main proceedings) 69 Grosvenor Street W1K 3JP - London - GB

Represented by Christoph Crützen

#### RESPONDENT

**ICPillar LLC** (Claimant in the main proceedings, hereinafter Respondent, Claimant or ICPillar) 4265 San Felipe Street, Suite 1100 77027 - Houston, Texas – US  
Represented by Lionel Martin

**PATENT AT ISSUE**

Patent no. Proprietor  
[EP3000239](#) ICPillar

**DECIDING JUDGES**

**COMPOSITION OF PANEL – FULL PANEL**

Presiding judge and Judge-rapporteur Camille Lignieres  
Legally qualified judge Carine Gillet

Legally qualified judge Petri Rinkinen

**LANGUAGE OF PROCEEDINGS:**

English

**ORDER**

**Summary of facts and procedure**

On 22 December 2023, ICPILLAR (Claimant in the main proceedings, Respondent in this Security for cost application) brought an infringement action against ARM's entities (Defendants in the main proceedings, Applicants in this Security for cost application, hereinafter also ARMs or ARM entities) based on European patent EP 3 000 239 (EP'239) before the Paris Local Division of the Unified Patent Court (UPC).

Defendants filed via an email due to technical issue with the CMS a Statement of Defence and a Counterclaim for Revocation.

On 26 April 2024, ARMs filed an application for security for legal costs in this proceeding pursuant to [Article 69\(4\) of the UPC Agreement \(UPCA\)](#) [and Rule 158.1](#) of the Rules of Procedure (RoP).

In the present application, ARMs (Applicants) are requesting that ICPILLAR (Respondent) is ordered to provide security for legal costs and other expenses in the amount of 800.000 euros within 6 weeks of date of service, by security deposit, or alternatively, by bank guarantee provided by a bank licensed in the EU, at the Court's discretion.

The Applicants submit that:

- First, Respondent's financial position is questionable, given that there are no public records about Respondent's assets, which raises a legitimate concern as to whether Respondent would have assets sufficient to cover a future costs order;

- Second, even assuming that Respondent has sufficient assets to cover a future costs order, enforcement would be unduly burdensome given that Respondent has connections to three different states in the United States (Texas, California, Delaware).

In response, ICPILLAR argues that:

- First, there is no risk that the Claimant will not be able to pay the costs of the proceedings if the case is dismissed by the Court as ICPILLAR has taken out a corresponding insurance policy to assure that a reimbursement of procedural costs due to ARMs for this UPC case will be covered and will not endanger ICPILLAR's economical standing.

The Respondent also argues that asking for security for costs in addition to this specific insurance will be a limitation to the right of effective remedy before a

tribunal (Art. 47 of the EU Charter of Fundamental Rights), and it will not be in respect of the principle of proportionality.

- Second, the enforcement of a potential cost order would not be unduly burdensome, as the enforcement in the United States can generally be recognized and enforced in the United States as the [UPC Munich LD](#) has already stated. ICPILLAR adds that they may be validly served with process before a Delaware state court for obtaining an exequatur judgement by delivering a copy of said process.

Furthermore, ICPILLAR argued that in case a bank guarantee is ordered, also a bank guarantee from a bank licensed in the United States should be accepted.

**Legal grounds**

[Article 69\(4\) UPCA](#) states that "At the request of the defendant, the Court may order the applicant to provide adequate security for the legal costs and other expenses incurred by the defendant which the applicant may be liable to bear, in particular in the cases referred to in Articles 59 to 62."

Pursuant to [R. 158.1 RoP](#), the Court may, at any stage of the proceedings, upon a reasoned request from one party, order the other party, within a specified period, to provide adequate security for the costs of the legal proceedings and any other costs incurred and/or yet to be incurred by the requesting party, which the other party may be required to bear. Before such an order is issued, the parties must be given the opportunity to be heard (R. 158.2 RoP). If the party affected by the order fails to comply with such an order, a decision by default may be issued against them.

When considering the assessment of security for costs, the Court shall take into account the main principles set out in the UPCA as regards to the Claimant's rights to an effective remedy and to a fair hearing and the principles set out in the RoP's Preamble, in particular the principle of proportionality.

**Grounds in the present case**

Central Division Munich has on its order delivered on [30 October 2023 \(UPC CFI 252/2023\)](#) given the following reasoning:

*"The Court has the discretion to order a security for legal costs and other expenses. Factors to be considered when ordering a security order include the financial position of the other party that may give rise to a legitimate and real concern that a possible cost order might not be recoverable and/or the likelihood that a possible cost order by the UPC may not, or in an unduly burdensome way, be enforceable. Imposing a security for legal costs serves to protect the position and (potential) rights of the Defendant.*

*This has to be balanced against the burden for the Claimant caused by an order to provide security. There should not be an unjustified interference with the right to an effective remedy and to a fair hearing. The Court must weigh the relevant facts and circumstances".*

This panel agrees with the reasoning above.

**On the criterion of difficulties in enforcing the decision:**

The risk of enforcement in the United States is not decisive in this case, as the place of registration of the company and the address of its main office are clearly indicated and not disputed.

In addition, the Court did not identify any particular difficulties in enforcing the UPC's decision in the United States of America, even if it has to be done in different states of the USA. As it has already been stated by the UPC Munich Local Division: *"In the United States of America, judgments of foreign courts as well as associated cost decisions can in principle be recognised and enforced. That this could be different with decisions and orders of this court or that this is seriously to be expected is neither submitted nor otherwise evident."*

(UPC CFI 15/2023 (LD Munich) Order of 29/09/2023). Even the Applicants noted in their application that *"it is true that judgments of foreign courts and the associated cost decisions can generally be recognized and enforced in the United States."* (point 21 of the Application)

In the present case, there are no exceptional circumstances that would be considered as unduly burdensome to justify the order. Nor does the mere fact that the Respondent is domiciled in the United States of America justify an order for security for costs.

**On the criterion of the claimant's financial situation:**

The criterion of the claimant's financial situation is decisive for the Court when it has to decide whether or not to order the security for the legal costs. The essential risk is that the lack of financial resources to pay the successful party's costs, which are to be borne by the losing party, may lead to a situation where the costs ordered cannot in reality be collected.

Applicants submitted that there are no public records about Respondent's assets and financial situation. They rightly pointed out that ICPILLAR presented itself in the statement of claim as a company founded in January 2021 by the inventor of the patent at issue, Mr. Seidner, and that ICPILLAR's only income was from the licensing of its patents. The official documents submitted did not provide any information about ICPILLAR's financial situation or its current assets.

Respondent in its written comments did not provide any indication of its financial situation.

The Court therefore considers that we are in a situation of a potential risk of inability to cover the legal costs of the other party in case of losing the litigation, taking into account the value of the case, even if this amount is disputed, being declared by the Claimant at 18,000,000 EUR and hence leading to ceiling of the legal costs for the amount of EUR 1,200,000.

The only response from ICPILLAR has been to provide an insurance broker's declaration that ICPILLAR has required an insurance that will cover to ICPILLAR the legal costs of the opposing party in this litigation up to the amount of EUR 800,000 in case ICPILLAR would be obliged to cover such costs (Exhibit 1-ICPILLAR-declaration of Mohsin Patel).

The main question in this context is therefore whether the insurance taken out by the Respondent to cover the financial risks in this case is sufficient and would

prevent it from being required to provide the security for costs as provided for in R. 158 RoP.

The insurance broker's declaration is not sufficient to justify that the legal costs can be recovered from it by ARM for two reasons. Firstly, the purpose of this type of insurance is to provide a financial protection for ICPILLAR (the insured party), and not to protect the potential rights of the ARM entities (the applicants of the Security for cost request). Secondly, the full terms of the said insurance have not been disclosed and it is hence unclear what are the actual terms of the insurance.

**On the amount and modalities of the Security:**

Concerning the amount of the Security, ARM entities submitted in their Security for costs application that the ceiling for recoverable costs (based on the value of the action declared by the claimant at the amount of 18,000,000 EUR) would be 1,200,000 euros. However, the value of the case and hence the ceiling for legal costs has not been decided by the Court at this stage of the proceedings. The Respondent has argued that the value of the case due to certain events after the statement of claim was lodged have caused the value of the case to drop to EUR 15,000,000 in which case the ceiling for costs would be EUR 800,000. Therefore, setting the amount of the Security at one third of the presumed maximum amount, i.e. EUR 400,000, as proposed by the respondent in its subsidiary submissions, appears as a reasonable and proportionate at this stage. As the Munich CD has already noted, "should an additional security be required at some point in time in view of the actual costs (to be) incurred in these proceedings, the Defendant can request an additional "security" at any time during the proceedings (Rule 158.1 RoP)". (UPC CFI 252/2023 (CD Munich)- Order of 30/10/2023)

In order to guarantee the secure recovery of the legal costs potentially due to ARM entities, which are all based in Europe and most of them in the EU, a bank guarantee by a bank licensed to operate in EU must be provided. The Respondent's request to approve also a guarantee from a bank licensed to operate in the United States of America is dismissed but at the same time the Court notes that there are banks that are licensed to operate in EU and in the United States of America and hence this dismissal is not unreasonable even in case of a Respondent who is domiciled in the United States of America.

For all these reasons, it does not appear that a deposit or bank guarantee of EUR 400,000 constitutes an unjustified interference with the right to an effective remedy and to a fair hearing.

Consequently, the application for the Security costs shall be admitted for the amount of 400,000 euros.

**ORDER**

For these grounds, having heard the parties, the Court:  
- Orders ICPILLAR to within six weeks of the date of service of this order provide security for legal costs and other expenses pursuant to Rule 158.1 RoP to the amount of EUR 400,000 (four hundred thousand euro) by way of deposit on the UPC account dedicated for security deposits, alternatively by way of bank guarantee

provided by a bank licensed in the EU, to be chosen by ICPILLAR.

- An appeal may be brought against the present order within 15 calendar days of its notification to the unsuccessful party pursuant to [Art. 73\(2\)\(a\) UPCA](#) and [Rule 220.2 RoP](#).

Delivered in Paris, on 21 May 2024.

C. Lignieres, Presiding judge and Judge-rapporteur

C. Gillet, Legally qualified judge

P. Rinkinen, Legally qualified judge

**Order Details**

Order no. ORD\_23494/2024 in ACTION NUMBER:  
ACT\_596432/2023

UPC number: UPC\_CFI\_495/2023

Action Type: Infringement Action

Related proceeding: Application no. 22767/2024

Application Type: Application for Security for costs ([R. 158.1 RoP](#))

-----