

UPC CFI, Regional Division Nordic-Baltic, 7 October 2024, Abbott v Dexcom

*analyte sensor and apparatus  
for insertion of the sensor*

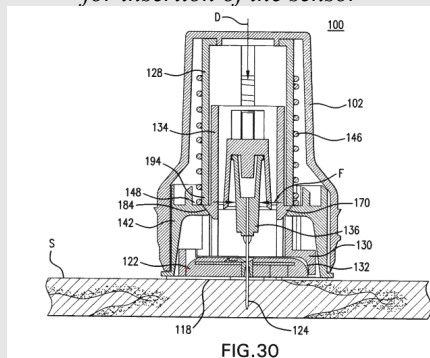

## PATENT LAW – PROCEDURAL LAW

Order following interim conference ([R. 105 RoP](#))

Request to change claim dismissed ([R. 263 RoP](#))

- [Request should have been in the application, not in an annex; changes asked are not mere corrections, could have been formulated earlier and extend the scope of the injunction.](#)
- [No need for alternative claims as the Court may grant the relief in full or in part as requested \(Article 76.1 UPCA\)](#)

The Court is in the position that alternative claims provided by the Claimant, are not needed as the Court may grant the relief in full or in part as requested according to the [art 76.1 UPCA](#). It stipulates that the Court shall decide in accordance with the requests submitted by the parties and shall not award more than is requested, meaning that the Court may award less or grant the claim partly.

Application to provide information dismissed as disproportionate ([Article 67 UPCA](#), [Article 8 Enforcement Directive](#), [Rule 191 RoP](#))

- [The Court order has to be as precise as possible, so that the obligated person may understand without a doubt what kind of information one has to provide.](#)

Heller document dismissed as late filed ground for revocation ([R. 44 RoP](#))

- [The Heller document was submitted to the Court by Defendants on 12 August 2024 in its Reply to the Defence to Revocation. The Court is in the position that all the ground for revocation should have been presented in the counterclaim.](#)

The Court is also in the position, that the Court can dismiss a part of the pleadings and the documents (evidence) submitted in support of the factual allegation or legal reasoning.

Source: [Unified Patent Court](#)

UPC Court of First Instance,  
Regional Division Nordic-Baltic, 7 October 2024  
(Härmand)

UPC\_CFI\_430/2023

**Preliminary Order**

of the Court of First Instance of the Unified Patent Court delivered on 10/7/2024

**CLAIMANT**

**1) Abbott Diabetes Care Inc.** (Claimant) - 1360 South Loop Road - 94502 - Alameda - US

Represented by Wim Maas

**DEFENDANTS**

**1) Dexcom Inc.** (Defendant) - 6340 Sequence Drive - 92121- 4356 - San Diego - US

Represented by Tjibbe Douma

**2) Dexcom International Limited** (Defendant) - Lampousas Street - 1095 - Nicosia - CY

**PATENT AT ISSUE**

Patent no. Proprietor/s

[EP3977921](#) Abbott Diabetes Care Inc.

**DECIDING JUDGE**

Kai Härmand

**COMPOSITION OF PANEL – FULL PANEL**

Presiding judge Stefan Johansson

Judge-rapporteur Kai Härmand

Legally qualified judge Pierluigi Perrotti

**LANGUAGE OF PROCEEDINGS:** English

**SUBJECT-MATTER OF THE PROCEEDINGS**

Infringement action and counterclaim for revocation

**SUMMARY OF FACTS**

Abbot Diabetes Care Inc (Claimant) filed infringement action against Dexcom Inc (Defendant I) and Dexcom International Limited (Defendant II) regarding the EP patent [3977921 B1](#) (EP 921) on 20.11.2023. Defendants filed counterclaim for revocation on 28.03.2024.

The parties have submitted various applications in relation to the main proceeding. The Claimant has submitted an Application for an Order to communicate information (35051/2024), an Application for leave to change claim (35044/2024) and a Request that Dexcom’s grounds for revocation based on one of the submitted documents are dismissed (49195/2024).

The Defendants have in the Statement of Defence requested security for legal costs.

Due to the requested change of the Statement of Claim, Dexcom Inc and Dexcom International Limited (“The Defendants”) have been granted leave not to file their Rejoinder to the Reply to the Statement of Defence until it is determined which Statement of Claim will be in force. Similarly, the Claimant has been authorized to refrain from filing any further submissions in the form of a Rejoinder to the Reply to the Defence to the Counterclaim and a Reply to the Defence to the Application to Amend the Patent.

The Court held interim conference on 30.09.2024 without closing the written procedure to discuss:

- Abbott’s Application for an Order to communicate information (35051/2024);

- Abbott’s Application for leave to change claim (35044/2024);

- Abbott's request that Dexcom's grounds for revocation based on the Heller document are dismissed (49195/2024);
- Pending EPO opposition proceedings;
- Deadlines for further written procedure;
- Practical issues relating to the oral hearing, e.g. estimated time, potential witnesses, etc.

### GROUND FOR ORDER

The order deals with request submitted to the Court during the written procedure. The order also gives procedural deadlines for the further written procedure and to prepare the oral hearing according to the [Rule 105.5 RoP](#).

The Court will decide the value of the case according to the [Rule 104 \(i\) and \(j\)](#), also the application of the [Art 33\(3\) UPCA](#) in a separate order.

### Allocation of a technically qualified judge

The Court discussed the technical field with the parties at the interim conference and asked the President of the Court of First Instance to allocate a technical judge.

### Application for leave to change the prayer

The Claimant applies for leave to change its prayer for relief and argues, that the amendments made to the prayer for relief constitute a correction to clarify what has already been asserted by the Claimant and do not qualify as a change of its claims (App\_35044/2024).

The Defendants requests to dismiss the application and/or not grant the requests According to the [Rule 263.1 RoP](#) a party may apply to the Court for leave of change its claim or to amend its case. According to the [Rule 263.2 \(a\) and \(b\) RoP](#) the leave shall not be granted if the party seeking the amendments fails to explain why the amendments could not have been made with reasonable diligence at an earlier stage. The amendments should not unreasonably hinder the other party in the conduct of its action.

The Court dismisses the request. First of all, the reasoning of the request should have been included in the application, not in the annex. In the adversarial, front-loaded procedure, the Court is not obliged to look for party positions and circumstances in the documents accompanying the application, but the rezoning must be included in the application.

For the sake of clarity, and as the application was explained during the interim conference, the Court takes its position also on the merits of the application. The Court is in the position that the changes asked by Abbott, are not just mere corrections. The Claimant wants to substitute in claim 1.1. a, b and e "the Defendants, individually and jointly" with "the Defendants, individually and/or jointly". The alleged infringing actions have been taken place already, so the circumstances of the case have not changed. The Claimant, having doubts of the involvement of both Defendants in the infringing activity, had the possibility to formulate its claim accordingly. Added "or" to the claim extends the scope of an injunction.

The Claimant asks to add "contributing to infringement" to claim 1.1. a and e. and "the G7 App and/or the G7 Receiver) or components thereof" to claim 1.1. b. The Court discussed "contributory infringement" during the

interim hearing with the parties as the term is not used in the UPCA. The mere fact that a term is not used in the UPCA, is not a ground for refusal, but the Court is in the position that proposed amendments also extend the scope of the claim. The Claimant initiated proceedings based on direct and indirect infringement. There is no mentioning of any Defendants contributing to the infringement. If the term "contributing to infringement" is alternative wording to indirect infringement, there is no need to amend the claim, as indirect infringement is in the claim. In case the Claimant meant something else with "contributing to infringement", then it is considered expansion of the claim and it is not grounded as the circumstances of the case have not changed.

The Court is in the position that alternative claims provided by the Claimant, are not needed as the Court may grant the relief in full or in part as requested according to the [art 76.1 UPCA](#). It stipulates that the Court shall decide in accordance with the requests submitted by the parties and shall not award more than is requested, meaning that the Court may award less or grant the claim partly.

### Application to provide information

The Claimant seeks an order pursuant to [Rule 191](#) in response to the Dependents argumentation that it has been not sufficiently proven that Defendants are committing infringing acts. The Claimant argues, that Dexcom did not dispute the same in the parallel proceedings before the Munich Local Division of this Court in the case regarding EP4087195 with case number 584295/2023. Despite having placed test purchases and having submitted a broad variety of supporting evidence, the facts of this case are that Dexcom has contested that Dexcom Inc. and Dexcom International are responsible for offering, supplying and/or placing the G7 System on the market. Therefore, Abbott requests this Court to order Dexcom to communicate how the distribution of the G7 System is arranged.

Defendants asked the Court to dismiss the application. Abbott filed identical applications in the parallel proceedings before the Paris Local Division (ACT\_587074/2023 involving EP 3 988 471) and The Hague Local Division (ACT\_586899/2023 involving EP 4 070 727). The Paris Local Division has dismissed Abbott's identical application.

The Defendants are in the position, that the application is inadmissible. It is not substantiated and Abbott abuses [R. 191 RoP](#) in an attempt to reverse the burden of proof. Abbott already has sufficient information regarding the distribution chain of the G7 System, based on publicly available information, and therefore does not justify why the information requested would be necessary to advance its case. Abbott had identified local distributors of Dexcom's products, but chose not to sue them in these proceedings. The application is clearly disproportionate and require disclosing Defendants confidential business information. It is contrary to the front-loaded nature and efficiency of UPC proceedings. The information has to be sufficient before filing the claim.

During the interim conference the Court discussed with the parties the meaning of “justified and proportionate”. The Court find the application admissible, but not justified.

[Art. 67 UPCA](#) stipulates that the Court may, in response to a justified and proportionate request of the applicant and in accordance with the Rules of Procedure, order an infringer to inform the applicant of: (a) the origin and distribution channels of the infringing products or processes; (b) the quantities produced, manufactured, delivered, received or ordered, as well as the price obtained for the infringing products; and (c) the identity of any third person involved in the production or distribution of the infringing products or in the use of the infringing process. [Rule 191 RoP](#) stipulates that the Court may in response to a reasoned request by a party order the other party or any third party to communicate such information in the control of that other party or third party as is specified in [Article 67](#) of the Agreement or such other information as is reasonably necessary for the purpose of advancing that party’s case. [Rule 190.1](#) second sentence, .5 and .6 shall apply mutatis mutandis. The right to information is also regulated in the Directive 2004/48/EC of the European Parliament and of the Council of 29 April 2004 on the enforcement of intellectual property rights ([Enforcement Directive](#)). Therefore [art 67 UPCA](#) and [Rule 191 RoP](#) have to be interpreted in the light of Enforcement Directive. This Court follows the approach of the Paris and Dusseldorf LD in the interpretation of the law. The fact that the Claimant chose to litigate only against the Defendants and not file a claim against local distributors, does not diminish the possibility to ask for distribution information. [Rule 191](#) has to be interpreted widely and the request for information may be invoked at different stages of the procedure- during the written or interim proceedings and also during the separate procedure for damages. Therefore, the application is admissible.

As regards the present dispute, the Court notes that the application is not justified because first of all there are evidence already presented by the Claimant. The Defendants did not contest the facts at the interim conference, but they contested the legal interpretation of the facts. The assessment of evidence is a substantive aspect that the Court will consider in the judgment. Second of all, the application is too broad in its essence.

At the interim conference, the Court discussed the matter with the parties and pointed out that the request may mean that detailed information like invoices, shipment documents are presented, or it may mean mere declaration of the distribution chain by the management of the Defendants. The Court order has to be as precise as possible, so that the obligated person may understand without a doubt what kind of information one has to provide. Therefore, the application is dismissed as unproportionate.

#### **Requests that grounds for revocation based on the Heller document are dismissed**

The Claimant filed the request to exclude Heller document as prior art. Heller document was included by

Defendants on 12 August 2024 in its Reply to the Defence to Revocation as evidence D24.

The Claimant argues, that the submission of new grounds for revocation, that were not included in the Counterclaim for Revocation, is contrary to the frontloaded character of the UPC proceedings. [UPC Central division \(Paris seat\) issued decision on 29 July 2024 between Bitzer Electronics A/S and Carrier Corporation](#) and stated that new grounds for revocation are inadmissible as they are not permitted by the Rules of Procedure and, in general, are contrary to the front-loaded character of the ‘UPC’ proceedings.

Dexcom submitted Heller in alleged response to Abbott’s position that claims 1 and 5 cover an integrated analyte monitoring assembly, i.e. sensor and sensor electronics that are integrated prior to sensor insertion. The filing of Heller was not triggered by something new that was stated in Abbott’s Defence to the Counterclaim or its Conditional Amendment Application, but rather invoked against claims 1 and 5 of the Patent as granted based on Abbott’s original construction of such claims as set out in its Statement of Claim dated 20 November 2023. Nevertheless, should the Court decide to allow Heller into the proceedings, Abbott must be given the opportunity to assess whether further conditional amendments to the Patent should be suggested.

The Defendants replied orally at the interim conference and asked the Court to dismiss the application.

The Court finds the application justified and the Heller document is dismissed from the file. The UPC procedure is front-loaded procedure and the ground for revocation and the supporting documents for that should have been submitted with the counterclaim. According to the [Rule 25 1 \(b\), \(c\) and \(d\)](#) the counterclaim for revocation has to include all the grounds for revocation, the facts and evidence relied on.

The Heller document was submitted to the Court by Defendants on 12 August 2024 in its Reply to the Defence to Revocation. The Court is in the position that all the ground for revocation should have been presented in the counterclaim. The Court is also in the position, that the Court can dismiss a part of the pleadings and the documents (evidence) submitted in support of the factual allegation or legal reasoning.

#### **The deadlines for the further proceedings and the oral hearing**

The Court discussed the procedure and the oral hearing with the parties. The parties agreed to file their positions within one month and final reply within another one month. According to the [Rule 29 \(d\)](#) and [32.3 RoP](#) the parties are invited to file the Rejoinder to the Reply to the Statement of Defence and the Rejoinder to the Reply to the Defence to the Counterclaim and a Reply to the Defence to an Application to Amend the Patent. The parties indicated at the interim conference that they want to present expert evidence before the oral hearing. The parties are invited according to the [Rule 176 8a\), \(b\) and \(c\)](#) to set out relevant information and to clarify in a concise manner the reasons to hear expert witnesses and specify the specific technical issues on which experts will be heard in their first submissions to the Court. The

Claimant is also invited to give written comment to the request for the security of legal costs.

**ORDER**

1. Dismiss the application to amend the prayer.
2. Dismiss the application to provide information
3. Dismiss the grounds for revocation based on the Heller document.
4. The parties are invited to present Rejoinder to the Reply to the Statement of Defence and the Rejoinder to the Reply to the Defence to the Counterclaim and a Reply to the Defence to an Application to Amend the Patent and the Rejoinder within two months.
5. The parties are invited to indicate the information set out in [Rule 176 RoP](#).
6. The Claimant is invited to give written comment to the request for the security of legal costs.
7. The oral hearing will take place 19.12.2024 at the Nordic-Baltic Regional Division in Stockholm.
8. The hearing of the party experts will take place 18.12.2024 at the Nordic-Baltic Regional Division in Stockholm.
9. The Court and the Registry will inform the parties of the exact time and location of the hearing in due time.

**ORDER DETAILS**

Order no. ORD\_ 55063/2024 in ACTION NUMBER:  
ACT\_588346/2023 and ACT\_14848/2024

UPC number: UPC\_CFI\_430/2023

Action type: Infringement Action and counterclaim

Related proceeding no 35051/2024; 35044/2024;  
49195/2024.

Kai Härmand

-----