

UPC Court of Appeal, 9 October 2024, Eoflow v Insulet

fluid delivery device with transcutaneous access tool, insertion mechanism and blood glucose monitoring for use therewith

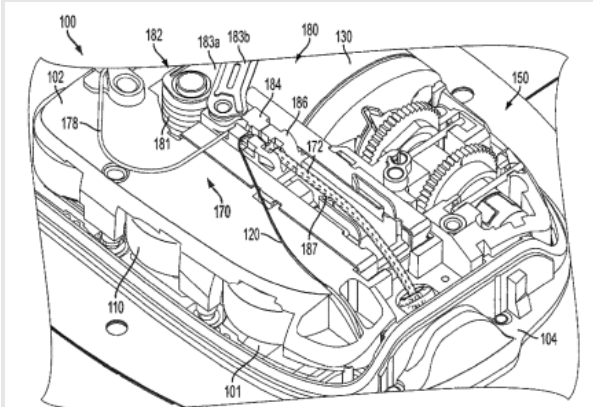

FIG. 1

PATENT AND PROCEDURAL LAW

Request for expedition of the appeal admissible but unfounded (R. 9.3(b) RoP, R. 235 RoP)

- [...] EOfFlow has not sufficiently substantiated, and the Court of Appeal fails to see, why it was necessary for EOfFlow to await the decision of the Central Division on Menarini's request for intervention, before filing the present request. By nevertheless doing so and taking ten days to file its Statement of appeal and grounds of appeal and this request, an order of the Court of Appeal would only be possible prior to the aforementioned oral hearings if Insulet would be given substantially less time for filing its response.

- The Court of Appeal is of the opinion that EOfFlow has thus by filing its request at an unnecessary late point of time, insufficiently taken into account the interests of Insulet.

17. In view of the interests of and the principles of proportionality, fairness and equity, and taking into account the above as well as the time period EOfFlow itself has taken to lodge its Statement of appeal and grounds of appeal – which is substantially longer than the time period Insulet could be given to lodge its Statement of response – the Court of Appeal cannot see a justification to shorten the time period within which Insulet is to lodge its Statement of response as requested by EOfFlow. The request shall be rejected.

Source: [Unified Patent Court](#)

UPC Court of Appeal, 9 October 2024

(Kalden, Simonsson, Rombach)

UPC_CoA_584/2024

PR_APL_54646/2024

App_50666/2024

Order

of the Court of Appeal of the Unified Patent Court issued on 9. October 2024

concerning a request for expedition of the appeal pursuant to [R.225\(e\)](#), [R.9.3\(b\)](#) Rules of Procedure

APPELLANT (AND APPLICANT AND DEFENDANT BEFORE THE COURT OF FIRST INSTANCE)

EOfFlow Co., Ltd., Hwangsaeul-ro, Bundang-gu, Seongnam-si, Gyeonggi-do, Korea (hereinafter 'EOfFlow')

represented by Rechtsanwalt Dr. Mirko Weinert

(HOYNG ROKH MONEGIER, Düsseldorf, Germany)

RESPONDENT IN THE APPEAL (AND APPLICANT BEFORE THE COURT OF FIRST INSTANCE)

Insulet Corporation, Acton, United States of America (hereinafter Insulet)

represented by Rechtsanwalt Dr. Marc Grunwald,

(Peterreins Schley, Munich, Germany)

LANGUAGE OF THE PROCEEDINGS

English

PATENT AT ISSUE

Patent no. [EP4201327](#)

PANEL AND DECIDING JUDGES

Second panel, consisting of

Rian Kalden, Presiding judge and legally qualified judge

Ingeborg Simonsson, legally qualified judge

Patricia Rombach, legally qualified judge and judge-rapporteur

IMPUGNED ORDER OF THE COURT OF FIRST INSTANCE

□ [24 September 2024, ORD 51234/2024, App 50666/2024, UPC CFI 380/2024](#)

□ in the main proceedings ACT_39640/2024, Milan Central Division

SUMMARY OF FACTS

1. On 3 July 2024 Insulet filed an application for provisional measures before the Central Division Milan against EOfFlow for alleged infringement of the European patent with unitary effect 4201327 (patent in suit) by making, offering and selling of insulin pumps labelled as 'EOPatch' and 'Glucomen Day pump' (attacked embodiments).

2. On 8 July 2024 Insulet filed an application for provisional measures before the Local Division Milan (App_39640/2024, UPC_CFI_400/2024) against A. Menarini Diagnostics s.r.l. (hereinafter Menarini) for alleged infringement of the patent in suit by offering and selling the attacked embodiments.

3. EOfFlow had requested before the Central Division Milan to order that the parallel actions UPC_CFI_380/2024, currently pending with the Central Division Milan, and UPC_CFI_400/2024, currently pending with the Local Division Milan be heard together by the Local Division Milan (R.340.1 RoP).

4. By Final Order of 4 September 2024 the judge-rapporteur denied the joinder-request. In [the impugned order the panel](#), in the panel review pursuant to [R.333 RoP](#) requested by EOfFlow, confirmed the order of the judge-rapporteur.

5. On 16 September 2024 Menarini filed an application to intervene, based on the facts that a decision in the present case would affect the legal interests of Menarini regarding the contractual relationship towards EOFLOW (the manufacturer of the attacked embodiments, i.e. upstream) as well as the contractual relationships of Menarini towards its customers (i.e. downstream). EOFLOW lodged a respective application to intervene in the parallel case before the Local Division Milan. With order of 1 October 2024 (ORD_52068/2024) the Central Division Milan rejected Menarini's request for intervention.

PARTIES' REQUESTS

6. In the present appeal proceedings, EOFLOW requests that the impugned order be set aside and order that the parallel action currently pending before the Central Division Milan, and action UPC_CFI_400/2024, currently pending before the Local Division Milan, are heard together by the Local Division Milan.

7. In the present application EOFLOW requests the Court of Appeal to expedite the appeal and shorten any deadlines where possible in accordance with [R.9.3 \(b\) RoP](#).

PARTIES' SUBMISSIONS

EOFLOW is submitting the following:

8. As the date for the oral hearing in the proceedings for provisional measures at the Local Division Milan and the Central Division Milan are set already for 15 October 2024 (UPC_CFI_400/2024) and 16 October 2024 (UPC_CFI_380/2024), there is a need for an expedition of the present appeal.

9. Only in case of an expedited appeal would it be possible to join the cases in question prior to an oral hearing in the first instance.

10. The present appeal could not have been filed earlier, since the decision by the Central Division Milan rejecting the application for invention, was issued on 1 October 2024.

REASONS

11. The request for expedition is admissible.

12. There is no need to consult Insulet in view of the outcome.

13. Pursuant to [R.235](#) and [R.224.2\(b\) RoP](#), a respondent has 15 days from service of the Statement of grounds of appeal to lodge a Statement of response. [R.9.3\(b\) RoP](#) empowers the Court to shorten any time period on a reasoned request by a party.

14. The request for expedition is unfounded.

15. The arguments brought forward by EOFLOW are insufficient to outweigh the interests of the respondent and due process and do not justify an expedition of the appeal as requested by EOFLOW.

16. EOFLOW requests the Court of Appeal to issue an order prior to the oral hearings in the first instance scheduled to take place on 15 October 2024 and 16 October 2024. In view of EOFLOW's stated interest to have the cases at first instance joined in order to prevent irreconcilable decisions, EOFLOW has not sufficiently substantiated, and the Court of Appeal fails to see, why it was necessary for EOFLOW to await the decision of the Central Division on Menarini's request for intervention,

before filing the present request. By nevertheless doing so and taking ten days to file its Statement of appeal and grounds of appeal and this request, an order of the Court of Appeal would only be possible prior to the aforementioned oral hearings if Insulet would be given substantially less time for filing its response. The Court of Appeal is of the opinion that EOFLOW has thus by filing its request at an unnecessary late point of time, insufficiently taken into account the interests of Insulet.

17. In view of the interests of and the principles of proportionality, fairness and equity, and taking into account the above as well as the time period EOFLOW itself has taken to lodge its Statement of appeal and grounds of appeal – which is substantially longer than the time period Insulet could be given to lodge its Statement of response – the Court of Appeal cannot see a justification to shorten the time period within which Insulet is to lodge its Statement of response as requested by EOFLOW. The request shall be rejected.

ORDER

The request for expedition of the appeal is rejected.

Issued on 9 October 2024

Rian Kalden, Presiding judge and legally qualified judge

Ingeborg Simonsson, legally qualified judge

Patricia Rombach, legally qualified judge and judge-rapporteur
