

UPC CFI, Central Division Paris, 14 October 2024,
Meril v Edwards

*a system comprising a prosthetic valve
and a delivery catheter*

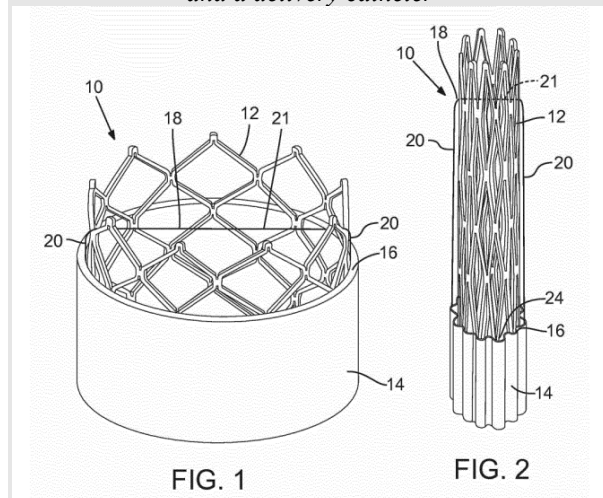

PATENT AND PROCEDURAL LAW

Unrestricted access granted to all pleadings and evidence in ended infringement proceedings and counterclaims for revocation ([Article 45 UPCA](#), [R. 262 RoP](#))

- [Generic interest: the mere fact of operating in the same field as the patent in dispute is not sufficient to establish a specific interest in the proceedings' documents on their part. Applicants' requests may not be considered insufficiently reasoned, because the fact that the applicants are carrying out preparatory activities to possibly enter the market concerned by the patent at issue is adequate to establish an interest in accessing the requested documents.](#)

Source: [Unified Patent Court](#)

UPC Court of First Instance,
Central Division Paris, 14 October 2024
(Catalozzi)

ORDER

of the Court of First Instance of the Unified Patent Court
Central division - Paris seat
issued on 14 October 2024
concerning the application [RoP 262.1\(b\)](#) Nos.
App_33486/2024, 33487/2024 and 33489/2024
lodged in the proceedings UPC_CFI_255/2023 and
counterclaims for revocation Nos. CC_584916/2023 and
CC_585030/2023

KEYWORDS: public access to the register

APPLICANT

[...] [...]

SWAT Medical AB - Drottninggatan 11 - 25284 -
Helsingborg – SE represented by [...]

RESPONDENTS

Meril Italy S.r.l. - Piazza Tre Torri 2, 20145 Milano,
Italy

represented by Emmanuel Larere and Jean-Hyacinthe de
Mitry, Cabinet Gide Loyrette Nouel AARPI, and by
Jonathan Stafford and Gregory Carty Hornsby, Marks &
Clerck LLP

Edwards Lifesciences Corporation - One Edwards
Way, Irvine, California, 92614, USA

represented by Siddharth Kusumakar, Tessa Waldron
and Bryce Matthewson, Powell Gilbert (Europe) LLP,
by Adam Rimmer, Powell Gilbert LLP, and by Jonas
Weickert and Bernhard Thum, Thum & Partner

Meril GmbH - Bornheimer Straße 135-137, 53119,
Bonn, Germany

Meril Life Sciences Pvt Ltd. - M10M2, Meril Park,
Survey No 135/2/B & 174/2, Muktanand Marg, Chala,
Vapi 396 191, Gujarat, India

both represented by Andreas von Falck, Alexander
Klicznik, Felipe Zilly, Roman Würtenberger and Lukas
Wollenschlaeger, Hogan Lovells International LLP and
assisted by Peter-Michael Weisse, Ole Dirks and Eva
Maria Thörner, Wildanger Kehrwald Graf v. Schwerin
& Partner mbB and Jonathan Stafford and Gregory
Carty-Hornsby, Marks & Clerk LLP

PATENT AT ISSUE:

European patent n. [EP 3 646 825](#)

PANEL:

Panel 2

Paolo Catalozzi Presiding judge and judge-rapporteur
Tatyana Zhilova Legally qualified judge
Stefan Wilhelm Technically qualified judge

DECIDING JUDGE:

This order is issued by the presiding judge and judge-
rapporteur Paolo Catalozzi

SUMMARY OF FACTS AND PARTIES' REQUESTS:

1. On 5 June 2024 the applicant filed an application, pursuant to [Rule 262 \(1\) \(b\) of the Rules of Procedures \('RoP'\)](#), registered as No. App_33486/2024, seeking access to all pleadings and evidence in the revocation action proceedings between Meril Italy s.r.l. and Edwards Lifesciences Corporation (registered as No. ACT_53108/2023 UPC_CFI_255/2023).
2. On the same date the applicant filed similar applications, registered as Nos. App_33487/2024 and 33489/2024, seeking access to all pleadings and evidence in the counterclaims for revocation proceedings between Meril GmbH and Meril Life Sciences Pvt Ltd., from one side, and Edwards Lifesciences Corporation from the other (registered, respectively, as Nos. CC_584916/2023 and CC_585030/2023 UPC_CFI_15/2023).
3. The access is requested as a member of the public, specifically as a board member and investor in a medical device company within the field of cardiac implant technology. The request is based on a direct interest and concern as a competitor regarding the validity of the patent in the proceedings with regard to a third-party product under development potentially similar to the allegedly infringing products of the defendants and

covered upon market entry by the granted claims of the present patent of the proceedings.

4. After the parties involved in the aforementioned proceedings submitted their comments, this judge-rapporteur, by order issued on 25 July 2024, requested the applicant to identify the third party who has an interest in the access to the sought documents as a competitor in the market concerned by the debated patent.

5. On 8 August 2024 the applicant amended the applications accordingly, clarifying that they were filed on his individual capacity as board member and investor in SWAT Medical AB and in the interest of SWAT Medical AB (named as 1st Co-applicant).

6. Then, on 22 August 2024 the respondents filed their comments.

7. Meril Italy s.r.l. requested that the judge-rapporteur: reject the application; as a subsidiary request, grant leave to appeal and suspend the effect the order pending the outcome of any appeal; grant access only to the documents relating exclusively to the validity of the patent at issue and exclude several specifically identified documents; order that such access is strictly confidential and personal to the applicants [...] and SWAT Medical AB); and reserve its right to seek damages before any competent court against the applicants.

8. Edwards Lifesciences Corporation requested that the application be dismissed; in the alternative, the application be dismissed to the extent that any written pleadings or evidence submitted by the parties that do not concern the patent in suit itself or its validity be excluded from access and that claimant is given the opportunity to specify the pleadings, sections thereof and evidence to be excluded within a deadline set by the Court; in the further alternative, in the event that the application is granted in full or in part, the applicant be ordered to keep the written pleadings and evidence he was given access to confidential, the Court grants leave to appeal the order granting access in full or in part and such order is not enforceable pending a final decision of the Court of Appeal. Finally, Edwards Lifesciences Corporation requested that the applicant be ordered to bear the costs of the proceedings relating to the access to register.

9. Meril GmbH and Meril Life Sciences Pvt Ltd. jointly requested that the application be rejected; in the alternative, the application be dismissed to the extent that any documents submitted with reference to or directly concerning the infringement proceedings and those specially identified; in case the application is granted in part or in full, it be ordered that the applicant is required to keep the documents he was given access to confidential and not to use the information obtained against counterclaimants. Finally, they requested that the applicants be ordered to bear the costs of the proceedings relating to the application for access to register.

GROUNDS OF THE ORDER

10. The distinct applications, each opened in a specific workflow, may be addressed jointly, as they have an identical content and relate to documents filed in

proceedings which have been consolidated. Therefore, these applications must also be consolidated.

Access to register

11. According to [Article 10 \(1\) of the Unified Patent Court Agreement \('UPCA'\)](#), “Subject to the conditions set out in this Agreement and the Rules of Procedure, the register kept by the Registry shall be public”. [Article 45 'UPCA'](#) adds that “The proceedings shall be open to the public unless the Court decides to make them confidential, to the extent necessary, in the interest of one of the parties or other affected persons, or in the general interest of justice or public order.”

12. [Rule 262 \(1\) \(b\) 'RoP'](#) specifies that “written pleadings and evidence, lodged at the Court and recorded by the Registry shall be available to the public upon reasoned request to the Registry: ...”.

13. As acknowledged by the Court of Appeal ([see order issued on 10 April 2024, UPC CoA 404/2023](#)), the aforementioned provisions make clear that the general principle laid down in the ‘UPCA’ is that the register is public and the proceedings are open to the public, unless the balance of interests involved is such that they are to be kept confidential, which means that in such case access to the public is to be denied.

14. Therefore, when a request to make written pleadings and evidence available to a member of the public is made pursuant to [Rule 262 \(1\) \(b\) 'RoP'](#), the interests of a member of the public of getting access to the written pleadings and evidence must be weighed against the interests mentioned in [Article 45 \('UPCA'\)](#). These interests include the protection of confidential information and personal data (‘the interest of one of the parties or other affected persons’) but also the general interest of justice, which includes the protection of the integrity of proceedings, and the public order.

15. In order to allow the judge-rapporteur to balance all the interests set forth in [Article 45 'UPCA'](#), the applicant must specify the purpose of the request and explain why access to the specified documents is necessary for that purpose, thus providing all the information.

16. It may be pointed out that a member of the public may have a specific interest in the subject-matter of the proceedings – such as the validity of a patent that he is also concerned with as a competitor or licensee, or where a party in that case is accused of infringing a patent by a product which is the same or similar to a product (to be) brought on the market by such member of the public – and in that case this interest does not only arise after the proceedings have come to an end but may very well be immediately present.

17. A member of the public may also have a generic interest that written pleadings and evidence are made available as this allows for a better understanding of the decision rendered and the scrutiny of the Court, which is important for trust in the Court by the public at large. This general interest of a member of the public usually arises after a decision was rendered or anyway the proceedings came to an end.

18. Once the proceedings come to an end the protection of the integrity of proceedings – which ensures that the

parties are able to bring forward their arguments and evidence and that this is decided upon by the Court in an impartial and independent manner, without influence and interference from external parties in the public domain – will not play a role. Given the general principle that the register and the proceedings are open to the public, the balance between the opposing interests against is usually in favour of allowing access, subject to the protection of personal data and confidential information.

19. In the present case, the applicants' interests have to be considered generic because the mere fact of operating in the same field as the patent in dispute is not sufficient to establish a specific interest in the proceedings' documents on their part. Indeed, it is not adequately alleged, nor much less proven, that the applicants are active competitors of the parties to the action, and, as such, concerned with the validity of the patent.

20. Nevertheless, according to this judge-rapporteur, access to the sought written pleadings and evidence has to be granted as the balance of opposing interests is favour of the disclosure. Indeed, applicants' requests may not be considered insufficiently reasoned, because the fact that the applicants are carrying out preparatory activities to possibly enter the market concerned by the patent at issue is adequate to establish an interest in accessing the requested documents.

21. Furthermore, the general interest of justice does not seem to play a role, as the proceedings have come to an end and, therefore, no need of protection of the integrity of these proceedings is present.

22. The same conclusions must be drawn with regard to the need to protect the public order, lacking elements displaying that the requests are abusive or may affect security interests.

23. In addition, no need to protect confidential information and personal data, which [Article 45 'UPCA'](#) refers to when it mentions the "*interest of one of the parties or other affected persons*", is asserted by the parties.

24. Meril Italy S.r.l., as well as Meril Gmbh and Meril Life Sciences Pvt Ltd., request that in case the access to the documents is granted it should be limited to those relating exclusively to the validity of the patent, with the exclusion of all documents (specifically indicating) relating to infringement or any potential further ancillary documents of the case.

25. This request shall not be granted as the right to access to case records is also provided, when the proceedings has come to an end, to enable a more thorough comprehension of the rationale for the judgment, in view of the arguments brought forward by the parties, and a scrutiny of the Court, which is important for trust in the Court by the public at large. This is possible only allowing access to all the documents which submitted to the Court or generated by the Court itself.

26. For the same reasons, and contrary to Edwards Lifesciences Corporation's argument, the declaration of validity of the patent in its amended version, stated in the decision on the revocation action and the counterclaims

for revocation, does not negate the applicants' interest in accessing the court records.

Requests to keep the documents confidential.

27. All the respondents request that in case the application is granted, the applicant be ordered to keep the written pleadings and evidence the applicant was given access to confidential. Meril Italy S.r.l. Meril Gmbh and Meril Life Sciences Pvt Ltd. further request that the applicant be ordered not to use the information obtained against them, either in court proceedings or out of court.

28. This request shall not be granted.

29. The Court's power to impose certain conditions on granting access, such as the obligation for that member of the public to keep the written pleadings and evidence he was given access to confidential, is intended to ensure the appropriate protection of the integrity of proceedings as long as the proceedings have not come to an end or of confidential information and personal data.

30. Neither of these situations is present as the proceedings have come to an end and no issue concerning the need of protection of confidentiality information has been duly submitted.

31. The right to access courts records implies that a party may use the information contained therein, which is to be considered public, both to examine and scrutinize the court's activities and to best guide its business activities. The use of such information in the exercise of one's business may, in certain circumstances, conflict with the interests of other companies, in relation to their position as competitors in the same market, but this does not in itself constitute an unlawful activity, as it is required for this purpose that such activity be carried out in violation of the rules governing the conduct of business activities in the States involved.

Leave to appeal and suspension of the effect of the order.

32. This judge-rapporteur considers it appropriate to grant the leave to appeal of this order requested by the respondents, having regard to the need to establish a consistent jurisprudence with reference to access to register and to the volume of documents subject to the access request and the significance of the information contained therein.

33. For the same reasons and considering the practical irreversibility of the effects of an order granting access to court records, it is deemed appropriate to suspend the effects of the present order until the expiration of the deadline for filing an appeal or, if an appeal is filed, until the end of such proceedings.

ORDER

The judge-rapporteur,

having regard to [Rule 262 \(1\) \(b\) 'RoP'](#),

- grants the applications filed on 5 June 2024, as amended on 8 August 2024, by and SWAT Medical AB, and, therefore, grants them access to all pleadings and evidence in the proceedings UPC_CFI_255/2023 and counterclaims for revocation Nos. CC_584916/2023 and CC_585030/2023;

- grants Meril Italy S.r.l., Edwards Lifesciences Corporation, Meril Gmbh and Meril Life Sciences Pvt Ltd. leave to appeal;
- suspends the effects of the present order until the expiration of the deadline for filing an appeal or, if an appeal is filed, until the end of such proceedings; - rejects all the remaining requests.

Issued on 14 October 2024

The presiding judge and judge-rapporteur

Paolo Catalozzi

ORDER DETAILS

Order no. ORD_36095/2024 in ACTION NUMBER:

ACT_551308/2023 UPC number: UPC_CFI_255/2023

Action type: Revocation Action Related proceeding no.

Application No.: 33486/2024 Application Type:

APPLICATION_ROP262_1_b
