

UPC CFI, Milan Central Division, 23 December 2024, Insulet v Menarini

*fluid delivery device with transcutaneous access tool, insertion mechanism and blood glucose monitoring for use therewith*

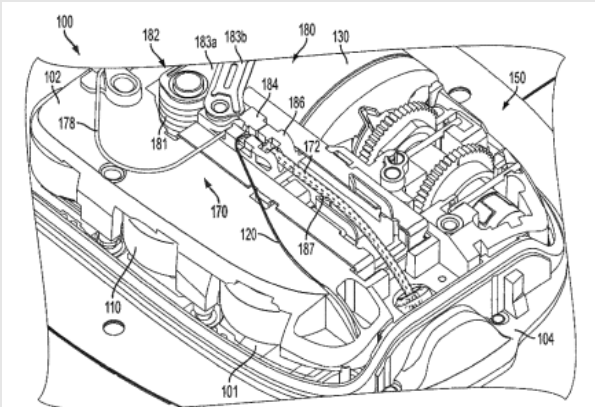

FIG. 1

## PATENT AND PROCEDURAL LAW

Cost decision to pay € 1,764 for legal costs regarding unsuccessful intervention

Application to intervene opens sub-proceedings ([R. 313 RoP](#))

- [The application to intervene under Rule 313, whatever its outcome, opens a sub-proceeding which requires the enforcement of the rule of law and leads either to the intervener's access to the proceedings \(so that the applicant becomes a "party" to those proceedings\) or to his exclusion. This decision is of a judicial nature and is taken after a comparative assessment of the parties' claims.](#)

Successful party in intervention sub-proceedings entitled to ask for legal costs compensation ([R. 151 RoP](#), [Article 69 UPCA](#))

- [in accordance with the general principle that the successful party is entitled to recover from the unsuccessful party the costs incurred in the proceedings.](#)
- [It does not appear necessary to attach an invoice for legal costs as long as it is clear and obvious what amounts are being claimed by the successful party and for what activities.](#)

Source: [Unified Patent Court](#)

UPC Court of First Instance,  
Milan Central Division, 23 December 2024  
(Postiglioni)

UPC\_CFI\_380/2024

### Procedural Order

of the Court of First Instance of the Unified Patent Court delivered on 23/12/2024

Date of receipt of Written Procedure : Not provided

APPLICANT/S

Insulet Corporation (Applicant) - 100 Nagog Park - MA 01720 - Acton - US

Represented by Marc Grunwald

### RESPONDENT/S

MENARINI DIAGNOSTICS s.r.l. Via dei Sette Santi n. 3 50131 Firenze with Counselor Christopher Maierhofer - Maximilianplatz 22 80333

Munich Germany

### PATENT AT ISSUE

Patent no. Proprietor/s

[EP4201327](#) Insulet Corporation

DECIDING JUDGE: Judge Rapporteur

LANGUAGE OF PROCEEDINGS: English

SUBJECT-MATTER OF THE PROCEEDINGS:

Proceeding for Costs decision

### ORDER

#### Headnotes

- 1) The intervener must prove an interest justifying the support to the reasons of one of the parties and, specifically, not a mere factual interest, but a legally qualified interest, determined by the need to prevent the repercussion, in its own legal sphere, of any harmful consequences deriving from the judgement.
- 2) Intervention pursuant to [Rule 313 RoP](#) is a sub-proceeding governed by rule of law in accordance with the adversarial principle. Applicant and respondent in the intervention proceedings must be considered as parties for the purpose of [Rule 150 RoP](#).
- 3) "Successful party" pursuant to [Rule 151](#) is to be considered the winning party at the outcome of said sub-proceedings. The party gaining access to the proceedings or successfully preventing the access of a third party into the proceedings are entitled to ask for legal cost compensation pursuant to [Art. 69 UPCA](#).
- 4) The assessment of proportionality and reasonableness of representation cost incurred by the winning party may be based on the fair assessment of the Court and does not require the issue of an invoice.

#### Keywords:

[RoP 150](#), [RoP 151](#), [RoP152](#), [RoP 313](#), [RoP 314](#), [Art. 69 UPCA](#)

#### SUMMARY OF FACTS

On 3 July 2024 INSULET co. Ltd., a US based company, filed an application for provisional measures for patent infringement against EOFLOW co. Ltd a Korean-based competitor (ref. UPC\_CFI 380/24) with the Central Division Milan.

The application was based on claims 1, 2, 3 and 4 of the European Patent with unitary effect UP 4 201 327 C0 granted on 19 June 2024 covering "fluid delivery device with transcutaneous access tool insertion mechanism and blood glucose monitoring for use therewith" for monitoring insulin levels in diabetic patients.

On 8 July 2024 INSULET filed a further – parallel – application for provisional measures against the exclusive European distributor of the attacked embodiment – A. Menarini Diagnostics s.r.l. (MENARINI in the suit) with Milan Local Division of the UPC.

Following this second PI request, and the rejection of a request for joinder of the two proceedings filed by EOFLOW on 16 September 2024, MENARINI lodged an application to intervene in the main proceedings UPC\_CFI 380/24 based on the facts that the outcome would affect its legal interests regarding both the contractual relationship towards Defendant (the manufacturer of the attacked embodiments, i.e. upstream) and the contractual relationships towards its customers (i.e. downstream).

EOFLOW supported the request of intervention with written submissions.

INSULET opposed the intervention pursuant to [Rule 314 RoP](#) (the payment of these pleadings as legal cost is the subject-matter of the present proceeding) and lodged written pleadings, pointing out that MENARINI had no legal interest to intervene in the case before the Central Division since it was already a party in the parallel proceedings (registered as UPC\_CFI\_400/24) and could express its points on both patent validity and infringement before the UPC Local Division Milan.

With [Order of 1 October 2024](#) the Panel of Milan Central Division rejected the request of intervention holding that *“Intervention in interim injunction proceedings is only available in exceptional cases. Following an interim injunction, proceedings on the merits must be initiated, ([R. 213.1 RoP](#)) within a short timeline... Interim injunction proceedings must not be overloaded, for example with interventions that could slow down the proceedings and, above all, can be made in proceedings on the merits...furthermore, MENARINI replied to the PI in the case before the LD on August 6th...MENARINI knew about the parallel proceeding already on August 6 th, but chose instead to intervene weeks later in proximity of the oral hearing and only after the Court rejected the request for joinder. This choice seems to be specious and not compatible to the already scheduled hearing for 16 October 2024”*

*The Court, in addition, observed “Moreover, pursuant to [Rule 313 RoP](#) intervention is allowed to a third party having its own interest not merely factual but legal. The third party must there-fore present itself as the owner of a legal relationship connected with the one brought in litigation by the counterpart or dependent on it, and the connection must entail a total or partial impairment of the right of which the third party claims to be the owner in the event the original party loses the case; that is to say, it is necessary to be the owner of a substantial situation connected with the relationship brought in litigation, such as to expose the third party to the reflexive effects of the judgement. In this case, however, the legal interest of MENARINI is already granted by way of defense in the parallel proceedings in front of UPC Milan Local Division”.*

Following rejection of the intervention request, the Court stipulated eventually that *“the successful party did not make a claim for costs. Since the costs of these proceedings cannot be recovered against Menarini in the main proceedings opposing INSULET and EOFLOW, INSULET may follow [RoP 151](#): “Where the successful party (hereinafter “the applicant”) wishes to*

*seek a cost decision, it shall within one month of service of the decision lodge an Application for a cost decision”.*

\*\*\*\*\*

In the following INSULET filed the present application (App. 58027/24) on 21.10.24 seeking for legal cost compensation against MENARINI as outcome of the defense activity performed against the intervention request. The request concerned the sum of 1.760- euro.

The request was served for comments to MENARINI on a web server, outside the CMS, since, as intervention was rejected, MENARINI had no visibility on the case documents, neither the CMS disposed of a specific workflow for intervention proceedings.

The Judge-Rapporteur gave a time limit for submission of defense submissions.

MENARINI lodged written pleadings objecting:

- (I) that the claim of payment of legal costs (following [151 RoP](#)) is reserved to the parties of the proceedings and that the intervener, according to [Rule 315.4 RoP](#), becomes a party only if intervention is granted.

- (II) that legal costs compensation might follow only a decision on the merits (quoting: *“There is, however, no article in the UPCA nor a rule in the Rules of Procedure directly addressing the cost issues in relation to interveners. [R. 150 et seqq.](#) provide a set of rules that only applies once ‘a decision on the merits’ has been made”*).

- (III) that the written submissions lodged by INSULET in the intervention proceedings were filed only on a voluntary basis and were therefore not eligible for reimbursement.

- (IV) that the amount of the costs was not demonstrated.

#### **REASONS FOR THE ORDER**

INSULET's application is well founded.

**As to Objection (I) "Menarini was not a party".**

The objection is unfounded.

Firstly, it should be noted that the application for costs was made by INSULET, which was a full party to the proceedings in which MENARINI sought to intervene, and that [Rule 151](#) refers generally to the "successful party" entitled to apply for a decision on costs. The rule does not exclude that an application for costs may also be made against a legal entity which is not yet a party to the proceedings. Secondly, a "party" to the proceedings is also a legal entity who brings a claim based on the assertion of his own right, on which the court is called upon to rule at the end of the proceedings, which are governed by legal rules and respect the adversarial principle.

The application to intervene under [Rule 313](#), whatever its outcome, opens a sub-proceeding which requires the enforcement of the rule of law and leads either to the intervener's access to the proceedings (so that the applicant becomes a "party" to those proceedings) or to his exclusion. This decision is of a judicial nature and is taken after a comparative assessment of the parties' claims.

In order to deny the jurisdictional nature of the order, it would not be worthwhile to argue that [Article 317 RoP](#)

does not allow an appeal against the decision to intervene. On the contrary, the absence of an appeal seems to be logically based on the need to ensure a speedy finalisation of the judgment.

The intervention in a case thus allows the participation in the judgment of a third party who, without proposing any further legal claims, expresses an interest in the success of one of the parties to the case in order not to suffer the consequences of an unfavourable judgment against the party he wishes to support. Therefore, [Rule 313](#) provides that *"an application to intervene may be made at any stage of the proceedings before the Court of First Instance or the Court of Appeal by any person having a legal interest in the outcome of the case. An application to intervene shall be admissible only if it is made in support, in whole or in part, of a claim, order or relief sought by one of the parties and before the closure of the written procedure, unless the Court of First Instance or the Court of Appeal decides otherwise"*.

As stated in CFI\_UPC 440/23 ([Paris LD case Laser Components s.a.s. v. Seoul Vysis Co.\) of 06.05.2024](#): *"The intervener shall have the rights attaching to the status of party and shall participate in the proceedings, subject, however, to [Rule 313.2 of the Rules of Procedure](#), to the condition that the intervention is made in whole or in part in support of a claim"*.

However, when [Rule 315.4](#) provides that the intervener is to be treated as a "party", it refers to the fact that intervention allows the party to enter a particular proceeding and to exercise - there - procedural rights.

The "successful party" within the meaning of [Rule 151](#) must therefore be considered not only in relation to the main proceedings against INSULET and EOFLOW, but also in relation to the sub-proceedings aimed at assessing the legal conditions for MENARINI's intervention.

And there is no doubt that MENARINI was a "party" to it, since it filed a claim and initiated legal proceedings (for intervention) against INSULET, which, on the other hand, successfully tried to keep MENARINI out of the main proceedings.

INSULET, as the successful party, must therefore be granted the right to claim legal costs, in accordance with the general principle that the successful party is entitled to recover from the unsuccessful party the costs incurred in the proceedings.

This principle is also clearly expressed in [Article 69 UPCA](#) and therefore applies as a general principle for the UPC: *"Reasonable and proportionate legal costs and other expenses incurred by the successful party shall, as a general rule, be borne by the unsuccessful party, unless equity requires otherwise, up to a ceiling set in accordance with the Rules of Procedure"*, so that it can apply to any litigation, including the one concerning intervention.

A fair reading of [Art. 69 UPCA](#), the general principles of law and the principle of equity enshrined in the [preamble to the Rules of Procedure](#) ("fairness and equity shall be ensured by having regard to the legitimate interests of all parties") leads to the conclusion that the loser must also bear the costs of

proceedings in the sub-proceedings concerning the intervention.

**As regards objection II. "Legal costs follow only decisions on the merits".**

The objection is unfounded.

MENARINI continues to maintain that legal costs can only follow a decision on the merits, asserting that there is no article in the UPCA or rule in the Rules of Procedure that directly addresses the issue of costs in relation to interveners. [R. 150 et seq.](#) provide a set of rules which only apply once a "decision on the merits" has been made (cf. [R. 150.1 sentence 1 RoP](#)).

A decision on the merits is a decision in which the court decides on the right claimed by one of the parties without stopping at a preliminary issue. And [Rule 150.1](#) provides that *"the decision on costs may be the subject of separate proceedings after a decision on the merits and, where appropriate, a decision on damages"*.

Again, the interpretation of [Rule 150.1 RoP](#) must be made in accordance with [Art. 69 UPCA](#), which refers to a general principle that the losing party must bear the costs of the proceedings.

[Art. 69 UPCA](#) does not distinguish between losing on the merits and losing on preliminary issues. According to MENARINI, legal costs would not be due if the case, although fully investigated, is terminated by a default decision under [Rule 355 RoP](#), e.g. if the party fails to comply with the instructions of the Judge-Rapporteur for the Interim Conference (see [Rule 103 RoP](#)). In many of these cases, there would already have been intensive defence activity, which should be compensated in the light of general principles of law.

It does not seem proportionate that only the costs of an action that ends the case on the merits should be compensated.

The [preamble to the RoP](#) clearly states that *"in the event of a conflict between the provisions of the Agreement and/or the Statute on the one hand and the Rules on the other, the provisions of the Agreement and/or the Statute shall prevail"*. In this case, it seems that the application of [Art. 69 UPCA](#), which does not limit the payment of costs to cases "on the merits", should prevail.

The preamble also states that *"the Rules shall be applied and interpreted in accordance with [Articles 41\(3\), 42 and 52\(1\) of the Agreement](#), on the basis of the principles of proportionality, flexibility, fairness and equity"*. This interpretation also seems to be more in line with the principles of proportionality and fairness, as the interpretation proposed by MENARINI leads to a disparity between substantive and non-substantive cases.

Furthermore, the Court considers that the decision on the right to intervene also entails a decision on the merits, in particular on the background to the right to intervene.

[RoP 314](#) provides that *"the judge-rapporteur shall decide on the admissibility of the application to intervene by way of an order"*, which means that the intervention procedure is indeed judicial in nature and subject to the adversarial right of defence (the hearing of all the parties is considered necessary in accordance with



**Rule 314 RoP** "The other parties shall be given an opportunity to be heard beforehand").

As a consequence, "an intervener is bound by the decision in the action" (see **RoP 316.3**), which means that, once this interest is recognised by the Court, his participation also exposes him to any possible outcome of the judgment.

The intervention procedure is governed by rules of law which give rise to substantive (**RoP 313.1** and **313.2**) and formal conditions of admissibility (**RoP 313.3** and **313.4**). Substantive conditions of admissibility involve a decision on the merits of the intervener's legal interest and the nature of its support for one of the parties.

It is no coincidence that the decision of 1 October 2024 in the leading case (**UPC CFI 380/24**) did not merely admit or reject the application, but also set out the substantive reasons why the application did not meet the legal requirements set out in **Rule 313 ss. RoP**.

The court's decision on the existence of a legal basis for intervention is therefore not merely formal, but goes into the substance of the intervener's rights, weighing up the arguments of both sides and placing them within the legal framework of **Rule 313 nos. 1) and 2) RoP**.

**As regards objection III. "that the written observations submitted by INSULET were submitted voluntarily."**

The objection is unfounded.

MENARINI points out that "there are no adverse procedural consequences for a party which decides not to submit observations on an application to intervene. Conversely, if a party decides to submit observations on an application to intervene, it does so in its own interest and at its own expense".

As stated above, the pleadings referred to in **Rule 314 RoP** are an expression of the right of defence and correspond to the principle of "parity of arms".

Moreover, it is not irrelevant whether a party faces one or more opponents, since the intervener may bring into the proceedings elements which the supported party has failed to exploit.

Finally, **Art. 69 UPCA**, as mentioned above, does not distinguish between "necessary" and "voluntary" defence and refers to all legal costs incurred, provided that they are reasonable and proportionate.

**As regards objection IV. "The amount of the costs is not proven".**

The objection is unfounded.

The Applicant wrote: "The costs incurred by the Applicant are reasonable as they were necessary for an adequate legal defence. The costs relate only to representation. Two lawyers (one partner and one associate, namely Dr Marc Grunwald and Maximilian Groß) were involved in reviewing the defendant's request and the corresponding court orders, as well as in preparing and filing the applicant's response to the request". An extract from the invoice or an advance invoice was then reproduced.

It does not appear necessary to attach an invoice for legal costs as long as it is clear and obvious what amounts are being claimed by the successful party and for what activities.

**RoP 151.1(d)** requires only "an indication of the costs for which compensation is claimed, which may include recovery of court fees and costs of representation, witnesses, experts and other expenses", while **RoP 152** allows the court to award "reasonable and proportionate costs of representation".

**RoP 152.2** provides that the costs of legal representation are to be linked to the value of the case and capped, below which the judge's assessment may apply, based on circumstantial or presumptive elements.

INSULET's request of only 1,764 euros seems proportionate to the preparation of a written submission, given the study that two lawyers had to carry out, the short time available to prepare it and the value of the case. This request is well below the value-limit set by the Court.

It must also be borne in mind that the evidential value of a document (in this case the extract) must be assessed not only on the basis of the document itself, but also on the basis of the circumstances in which it was drawn up and on the basis of the principles of proportionality and reasonableness.

Having regard to the reasonable amount of the invoice and the declaration of compliance issued by INSULET's lawyer, the Court has no doubt that the amounts set out in the excerpt invoice are plausible and proportionate and could correspond to the work actually carried out by the applicant's lawyers.

Since the time which has elapsed since the date of the decision (1.10.2024) does not justify the charging of interest, no interest will be payable on the amount awarded until one month after the date of the present decision.

Interest will be charged if payment is made after 25.1.2025.

Payment of the aforementioned amount must be made within 15 days of today's date (**Rule 156.3**).

#### **ON THESE GROUNDS**

The Court

- Orders MENARINI s.p.a. to pay to INSULET Co.Ltd the sum of 1,764 euros by 08.01.2025

- After 25/01/2025, interest shall accrue on this sum.

Done in Milan on 23 December 2024

Judge Rapporteur

Andrea Postiglione

**Rule 157** – Appeal against the cost decision

The decision of the judge-rapporteur as to costs only may be appealed to the Court of Appeal in accordance with **Rule 221**. Since this order touches on relevant issues, leave to appeal is granted.

#### **INFORMATION ABOUT ENFORCEMENT (RULE 68(1) RGR)**

##### **ORDER DETAILS**

Order no. ORD\_59988/2024 in ACTION NUMBER: Not provided

UPC number: UPC\_CFI\_380/2024

Action type: Not provided

Related proceeding no. Application No.: 39640/2024

Application Type: Application for provisional measures (**RoP 206**)

-----